



- Optional 2 additional - 10/100/1000BaseTX copper ports
- Long haul optics allow Gigabit distances up to 70km

Cyber Security Features

- Multi-level user passwords
- SSH/SSL (128-bit encryption)
- Enable/disable ports, MAC based port security
- Port based network access control (802.1x)
- VLAN (802.1Q) to segregate and secure network traffic
- RADIUS centralized password management
- SNMPv3 authentication and 56-bit encryption

RuggedRated™ for Reliability in Harsh Environments

- Immunity to EMI and heavy electrical surges
 - Meets IEEE 1613 (electric utility substations)
 - Exceeds IEC 61850-3 (electric utility substations)
 - Exceeds IEC 61800-3 (variable speed drive systems)
 - Exceeds IEC 61000-6-2 (generic industrial)
 - Exceeds NEMA TS-2 (traffic control equipment)
- Hazardous Location Certification: Class 1 Division 2
- -40 to +85°C operating temperature (no fans)
- Conformal coated printed circuit boards (optional)

Rugged Operating System (ROS®) Features

- Simple plug and play operation - automatic learning, negotiation, and crossover detection
- MSTP 802.1Q-2005 (formerly 802.1s)
- RSTP (802.1w) and Enhanced Rapid Spanning Tree (eRSTP™) network fault recovery (<5ms)
- Quality of Service (802.1p) for real-time traffic
- VLAN (802.1Q) with double tagging and GVRP support
- Link aggregation (802.3ad)
- IGMP Snooping for multicast filtering
- Port Rate Limiting and Broadcast Storm Limiting
- Port configuration, status, statistics, mirroring, security
- Industrial automation features (eg. Modbus)

Management Tools

- Web-based, Telnet, CLI management interfaces
- SNMP v1/v2/v3 (56-bit encryption)
- Remote Monitoring (RMON)
- Rich set of diagnostics with logging and alarms

Universal Power Supply Options

- Fully integrated power supply
- Universal high-voltage range: 88-300VDC or 85-264VAC
- Dual low-voltage DC inputs: 24VDC (10-36VDC) or 48VDC (36-72VDC)
- Terminal blocks for reliable maintenance free connections
- CSA/UL 60950 safety approved to +85°C

The RuggedSwitch® RS940G is an industrially hardened, fully managed Ethernet switch providing six or eight ports of Gigabit Ethernet. Six 10/100/1000BaseTX triple speed copper ports are standard. An additional two gigabit fiber or copper ports can be added. The RS940G provides a cost effective way of connecting a cluster of field devices to a Gigabit Ethernet backbone.

Designed to operate reliably in harsh industrial environments the RS940G provides a high level of immunity to electromagnetic interference and heavy electrical surges typical of environments found in electric utility substations, process control or in curb side traffic control cabinets. An operating temperature range of -40°C to +85°C coupled with hazardous location certification, optional conformal coating and a galvanized steel enclosure allows the RS940G to be placed in almost any location.

The embedded Rugged Operating System (ROS®) provides advanced networking features such as Enhanced Rapid Spanning Tree (eRSTPTM), Port Rate Limiting and a full array of intelligent functionality for high network availability and manageability.

The versatility and wide selection of fiber optics allows the RS940G to be used in a variety of applications. The RS940G provides two fiber optical Gigabit Ethernet ports for creating a fiber optical backbone with high noise immunity and long haul connectivity.

The embedded Rugged Operating System (ROS®) provides advanced layer 2 and layer 3 networking functions, and advanced cyber security features. Coupled with the ruggedized hardware design, RS940G is ideal for creating mission-critical, real-time, control applications where high reliability and availability is of paramount importance.

Features and Benefits

Ethernet Ports

- 6 - 10/100/1000BaseTX Triple Speed Copper Ports Standard
- Optional 2 additional 1000LX SFP Pluggable Gigabit Fiber



RuggedSwitch® RS940G

Gigabit Copper Ports:

- ▶ 6 - Triple Speed Copper Ports (10/100/1000BaseTX)

Rugged Construction:

- ▶ 20 AWG. galvanized steel enclosure
- ▶ Conformal coating (optional)

Hazardous Location Certification

- ▶ Class 1, Division 2

Integrated Power Supply

- ▶ Universal high-voltage range: 88-300VDC or 85 - 264VAC
- ▶ Popular low voltage DC ranges: 24VDC (10-36VDC), 48VDC (36-59VDC)
- ▶ Dual Isolated DC power inputs

Mounting Options

- ▶ DIN Rail
- ▶ Panel Mount

Optional Dual Gigabit Fiber Ports:

- ▶ Pluggable Optics (SFP)
- ▶ LC or SC connectors
- ▶ Distances up to 70km

Operating Temperature

- ▶ -40°C to +85°C
- ▶ No Fans

Critical Alarm Relay

- ▶ Form-C failsafe contact relay: 1A@30VDC



ROS® Features



Cyber Security

Cyber security is an urgent issue in many industries where advanced automation and communications networks play a crucial role in mission critical applications and where high reliability is of paramount importance. Key ROS® features that address security issues at the local area network level include:

- **Passwords** - Multi-level user passwords secures switch against unauthorized configuration
- **SSH / SSL** - Extends capability of password protection to add 128-bit encryption of passwords and data as they cross the network
- **Enable/Disable Ports** - Capability to disable ports so that traffic can not pass
- **802.1Q VLAN** - Provides the ability to logically segregate traffic between predefined ports on switches
- **MAC Based Port Security** - The ability to secure ports on a switch so only specific Devices / MAC addresses can communicate via that port
- **802.1x Port Based Network Access Control** - The ability to lock down ports on a switch so that only authorized clients can communicate via this port
- **RADIUS** - authentication service using MD5 hash and providing centralized password management
- **SNMPv3** - encrypted authentication access security and data encryption (CBC-DES with 56-bit encryption key)
- **Secure Socket Layer** - Web-based management using SSL with data encryption (128-bit encryption key)
- **RSA** - 1024 bit key for key management and key exchange
- **TACACS+** - Terminal Access Control and Accounting Services Client provides encrypted authentication and authorization
- **Point to Point (PPP)** - using CHAP (MD5 Hash) authentication service
- **SFTP** - Secure File Transfer Protocol using SSH encryption

The ROS® cyber security features are included to help address the various industry specific security standards such as NERC CIP, ISA S99, AGA 12, IEC 62443, ISO 17799:2005 and PCSRF SPP-ICS.

Enhanced Rapid Spanning Tree Protocol (eRSTP™)

RuggedCom eRSTP™ allows the creation of fault-tolerant ring and mesh Ethernet networks that incorporate redundant links that are 'pruned' to prevent loops. eRSTP™ yields worst-case fault recovery of 5ms times the 'bridge diameter' and allows rings of up to 160 switches. For example, a ring of ten switches will have fault recovery times under 50ms. eRSTP™ implements both STP and RSTP to ensure interoperability with commercial switches unlike other proprietary 'ring' solutions.

Quality of Service (IEEE 802.1p)

Some networking applications such as real-time control or VoIP (voice over IP) require predictable arrival times for Ethernet frames. Switches can introduce latency in times of heavy network

traffic due to the internal queues that buffer frames and then transmit on a first come first serve basis. ROS® supports 'Class of Service' in accordance with IEEE 802.1p that allows time critical traffic to jump ahead to the front of the queue thus minimizing latency and reducing jitter to allow such demanding applications to operate correctly. ROS® allows priority classification by port, tags, MAC address, and IP type of service (ToS).

A configurable "weighted fair queuing" algorithm controls how frames are emptied from the queues.

VLAN (IEEE 802.1Q)

Virtual local area networks (VLAN) allow the segregation of a physical network into separate logical networks with independent broadcast domains. A measure of security is provided since hosts can only access other hosts on the same VLAN and traffic storms are isolated. ROS® supports 802.1Q tagged Ethernet frames and VLAN trunks. Port based classification allows legacy devices to be assigned to the correct VLAN. GVRP support is also provided to simplify the configuration of the switches on the VLAN.

Link Aggregation (802.3ad)

The link aggregation feature provides the ability to aggregate several Ethernet ports into one logical link (port trunk) with higher bandwidth. This provides an inexpensive way to set up a high speed backbone to improve network bandwidth. This feature is also known as "port trunking", "port bundling", "port teaming", and "Ethernet trunk".

IGMP Snooping

ROS® uses IGMP snooping (Internet Group Management Protocol v1&v2) to intelligently forward or filter multicast traffic streams (e.g. MPEG video) to or from hosts on the network. This reduces the load on network trunks and prevents packets from being received on hosts that are not involved. ROS® has a very powerful implementation of IGMP snooping that:

- Can be enabled on a per VLAN basis.
- Detects and filters all multicast streams regardless of whether subscribers exist.
- Supports "router-less" operation by supporting an "active" mode.
- Restores traffic streams immediately after an RSTP topology change.

SNMP (Simple Network Management Protocol)

SNMP provides a standardized method for network management stations the ability to interrogate devices from different vendors. SNMP versions supported by ROS® are v1, v2c, and v3. SNMPv3 in particular provides security features (such as authentication, privacy, and access control) not present in earlier SNMP versions. ROS® also supports numerous standard MIBs (Management Information Base) allowing for easy integration with any network management system (NMS).

ROS® Features

A feature of SNMP supported by ROS® is the ability to generate “traps” upon system events. RuggedNMSTM, the RuggedCom management solution, can record traps from multiple devices providing a powerful network troubleshooting tool. It also provides a graphical visualization of the network and is fully integrated with all RuggedCom products.

1 eRSTP fault recovery times may be approximated as follows:
For 100 Mbps, fault recovery performance is <5ms/hop
For 1,000 Mbps, fault recovery performance is <5ms/hop + 20ms

SNTP (Simple Network Time Protocol)

SNTP automatically synchronizes the internal clock of all ROS® devices on the network. This allows for correlation of time stamped events for troubleshooting.

SCADA and Industrial Automation

ROS® contains features that optimize network performance and simplify switch management based on the unique requirements found in SCADA and industrial automation applications. Features such as Modbus TCP management for retrieval of switch data using the ubiquitous Modbus protocol and DHCP Option 82, a Rockwell Automation ODVA requirement for IP address assignment based on the location of the end device, provide capabilities not found in typical “commercial” or “office grade” Ethernet switches.

Port Based Network Access Control (802.1x)

ROS® supports the IEEE 802.1x standard that defines a mechanism for port-based network access control which provides a means of authenticating and authorizing devices attached to LAN ports.

Port Rate Limiting

ROS® supports configurable rate limiting per port to limit unicast and multicast traffic. This can be essential to managing precious network bandwidth for service providers. It also provides edge security for denial of service (DoS) attacks.

Broadcast Storm Filtering

Broadcast storms wreak havoc on a network and can cause attached devices to malfunction. This could be disastrous on a network with mission critical equipment. ROS® limits this by filtering broadcast frames with a user-defined threshold.

Loss of Link Management

Some intelligent electronic devices (IEDs) have dual fiber optic ports with automatic failover to a backup port should the primary fail. ROS® ensures this mechanism works reliably under all failure modes by appropriately disabling link signals when required. ROS® also flushes learned MAC addresses to ensure the failover occurs quickly.

Port Mirroring

ROS® can be configured to duplicate all traffic on one port to a designated mirror port. When combined with a network analyzer, this can be a powerful troubleshooting tool.

Port Configuration and Status

ROS® allows individual ports to be ‘hard’ configured for speed, duplex, auto-negotiation, flow control and more. This allows proper connection with devices that do not negotiate or have unusual settings. Detailed status of ports with alarm and SNMP trap on link problems aid greatly in system troubleshooting.

Port Statistics and RMON (Remote Monitoring)

ROS® provides continuously updating statistics per port that provide both ingress and egress packet and byte counters as well as detailed error figures. Also provided is full support for the RMON statistics, history, alarms, and event groups. RMON allows for very sophisticated data collection, analysis and detection of traffic patterns.

Event Logging and Alarms

ROS® records all significant events to a non-volatile system log allowing forensic troubleshooting. Events include link failure and recovery, unauthorized access, broadcast storm detection, and self-test diagnostics among others. Alarms provide a snapshot of recent events that have yet to be acknowledged by the network administrator. An external hardware relay is de-energized during the presence of critical alarms allowing an external controller to react if desired.

HTML Web Browser and Telnet User Interfaces

ROS® provides a simple, intuitive user interface for configuration and monitoring via a standard graphical web browser or via Telnet. All system parameters include detailed on-line help to make setup a breeze. ROS®, presents a common look and feel and standardized configuration process allowing easy migration to other RuggedCom managed products.

Configuration via ASCII Text File

All configuration parameters are stored in an ASCII formatted text file that can easily be transferred via TFTP or Xmodem. The configuration file can be saved for backup purposes and easily manipulated by a text editor. The same text file can be downloaded to the switch at a later date in order to re-configure or restore a previous configuration.

Command Line Interface (CLI)

A command line interface can be used in conjunction with remote shell to automate data retrieval, configuration updates, and firmware upgrades. A powerful SQL-like capability allows expert users the ability to selectively retrieve or manipulate any parameters the device has to offer.

EMI and Environmental Type Tests

| IEC 61850-3 EMI TYPE TESTS | | | | |
|----------------------------|-----------------------------|---------------------------------|--|-----------------|
| TEST | Description | | Test Levels | Severity Levels |
| IEC 61000-4-2 | ESD | Enclosure Contact | +/- 8kV | 4 |
| | | Enclosure Air | +/- 15kV | 4 |
| IEC 61000-4-3 | Radiated RFI | Enclosure ports | 20 V/m | x |
| IEC 61000-4-4 | Burst (Fast Transient) | Signal ports | +/- 4kV @ 2.5kHz | x |
| | | D.C. Power ports | +/- 4kV | 4 |
| | | A.C. Power ports | +/- 4kV | 4 |
| | | Earth ground ports ³ | +/- 4kV | 4 |
| IEC 61000-4-5 | Surge | Signal ports | +/- 4kV line-to-earth, +/- 2kV line-to-line | 4 |
| | | D.C. Power ports | +/- 2kV line-to-earth, +/- 1kV line-to-line | 3 |
| | | A.C. Power ports | +/- 4kV line-to-earth, +/- 2kV line-to-line | 4 |
| IEC 61000-4-6 | Induced (Conducted) RFI | Signal ports | 10V | 3 |
| | | D.C Power ports | 10V | 3 |
| | | A.C. Power ports | 10V | 3 |
| | | Earth ground ports ³ | 10V | 3 |
| IEC 61000-4-8 | Magnetic Field | Enclosure ports | 40 A/m continuous, 1000 A/m for 1 s | N/A |
| IEC 61000-4-29 | Voltage Dips & Interrupts | D.C. Power ports | 30% for 0.1s, 60% for 0.1s, 100% for 0.05s | N/A |
| IEC 61000-4-11 | | A.C. Power ports | 30% for 1 period, 60% for 50 periods 100% for 5 periods, 100% for 50 periods ² | N/A |
| IEC 61000-4-12 | Damped Oscillatory | Signal ports | 2.5kV common, 1kV diff. mode@1MHz | 3 |
| | | D.C. Power ports | 2.5kV common, 1kV diff. mode@1MHz | 3 |
| | | A.C. Power ports | 2.5kV common, 1kV diff. mode@1MHz | 3 |
| IEC 61000-4-16 | Mains Frequency Voltage | Signal ports | 30V Continuous, 300V for 1s | 4 |
| | | D.C. Power ports | 30V Continuous, 300V for 1s | 4 |
| IEC 61000-4-17 | Ripple on D.C. Power Supply | D.C. Power ports | 10% | 3 |
| IEC 60255-5 | Dielectric Strength | Signal ports | 2kVac (Fail-Safe Relay output) | N/A |
| | | D.C. Power ports | 1.5kV DC | N/A |
| | | A.C. Power ports | 2kVac | N/A |
| IEC 60255-5 | H.V. Impulse | Signal ports | 5kV (Fail-Safe Relay output) | N/A |
| | | D.C. Power ports | 5kV | N/A |
| | | A.C. Power ports | 5kV | N/A |

| IEEE 1613 (C37.90.x) EMI IMMUNITY TYPE TESTS | | | | |
|--|---------------------|---------------------------------|-----------------------------------|-----------------|
| Test | Description | | Test Levels | Severity Levels |
| IEEE C37.90.3 | ESD | Enclosure Contact | +/- 8kV | N/A |
| | | Enclosure Air | +/- 15kV | N/A |
| IEEE C37.90.2 | Radiated RFI | Enclosure ports | 35 V/m | N/A |
| IEEE C37.90.1 | Fast Transient | Signal ports | +/- 4kV @ 2.5kHz | N/A |
| | | D.C. Power ports | +/- 4kV | N/A |
| | | A.C. Power ports | +/- 4kV | N/A |
| | | Earth ground ports ³ | +/- 4kV | N/A |
| IEEE C37.90.1 | Oscillatory | Signal ports | 2.5kV common mode @1MHz | N/A |
| | | D.C. Power ports | 2.5kV common, 1kV diff. mode@1MHz | N/A |
| | | A.C. Power ports | 2.5kV common, 1kV diff. mode@1MHz | N/A |
| IEEE C37.90 | H.V. Impulse | Signal ports | 5kV (Fail-Safe Relay output) | N/A |
| | | D.C. Power ports | 5kV | N/A |
| | | A.C. Power ports | 5kV | N/A |
| IEEE C37.90 | Dielectric Strength | Signal ports | 2kVac | N/A |
| | | D.C. Power ports | 1.5kV DC | N/A |
| | | A.C. Power ports | 2kVac | N/A |

| Environmental Type Tests | | | | |
|--------------------------|------------------------------|----------|--------------------------------------|-----------------|
| Test | Description | | Test Levels | Severity Levels |
| IEC 60068-2-1 | Cold Temperature | Test Ad | -40°C, 16 Hours | N/A |
| IEC 60068-2-2 | Dry Heat | Test Bd | +85°C, 16 Hours | N/A |
| IEC 60068-2-30 | Humidity (Damp Heat, Cyclic) | Test Db | 95% (non-condensing), 55°C, 6 cycles | N/A |
| IEC 60255-21-1 | Vibration | Tests Fc | 2g @ (10 - 150) Hz | Class 2 |
| IEC 60255-21-2 | Shock | Tests Ea | 30g @ 11mS | Class 2 |

Notes:
 1. Only applicable to functional earth connections separated from the safety earth connection.
 2. Class 2 refers to "Measuring relays and protection equipment for which a very high security margin is required or where the vibration levels are very high, (e.g. shipboard application and for severe transportation conditions")

Technical Specifications

Power Supply

- Power Consumption: 18W Max
- 24VDC: 10-36 VDC, 0.4A
- 48VDC: 36-72 VDC, 0.2A
- HI Voltage AC/DC: 88-300VDC or 85-264VAC

Critical Alarm Relay

- Form-C failsafe contact relay: 1A@30VDC

Physical

- Height: 7.4"
- Width: 2.6"
- Depth: 5.0"
- Weight: 2.7lbs
- Ingress Protection: IP40 (1mm objects)
- Enclosure: 20 AWG galvanized steel enclosure
- Mounting: DIN rail or panel mounted

Switch Properties

- Switching method: Store & Forward
- Switching latency: 7 us
- Switching bandwidth: 16Gbps
- MAC addresses: 8192
- MAC address table size: 32kbytes
- Priority Queues: 4
- Frame buffer memory: 2 Mbit
- Simultaneous VLANs: 255
- VLAN ID Range: 1 to 4094
- IGMP multicast groups: 256
- Port rate limiting: 128kbps, 256, 512, 4, 8Mbps
- No head of line blocking

Approvals

- Hazardous Locations: Class 1, Division 2
- ISO: Designed and manufactured using a ISO9001:2000 certified quality program
- CE Marking
- Emissions: FCC Part 15 (Class A), EN55022 (CISPR22 Class A)
- Safety: cCSAus (Compliant with CSA C22.2 No. 60950, UL 60950, EN60950)
- Laser Eye Safety (FDA/CDRH): Complies with 21 CFR Chapter1, Subchapter J.

Warranty

- 5 Years - Applicable to design and manufacturing related product defects.

Network Management

- HTTP graphical web-based, SSL (128-bit encryption)
- SNMP v1, v2c, v3 (56-bit encryption)
- Telnet, VT100, SSH/SFTP (128-bit encryption)
- Command Line Interface (CLI)
- RSA Key Management (1024 bit key)
- Authentication and Accounting - TACACS+ (encrypted), RADIUS client, PPP

EMI Immunity and Environmental Compliance

- IEC 61000-6-2 Industrial (Generic)
- IEC 61800-3 Industrial (Variable Speed Drive Systems)
- IEWC 61850-3 Electric Utility Substations
- IEEE 1613 Electric Utility Substations
- NEMA TS 2 Traffic Control Equipment (pending)

IEEE Compliance

- 802.3-10BaseT
- 802.3u-100BaseTX, 100BaseFX
- 802.3x-Flow Control
- 802.3z-1000BaseLX
- 802.3ab-1000BaseTX
- 802.3ad-Link Aggregation
- 802.1D-MAC Bridges
- 802.1D-Spanning Tree Protocol
- 802.1p-Class of Service
- 802.1Q-VLAN Tagging
- 802.1w-Rapid Spanning Tree Protocol
- 802.1x-Port Based Network Access Control
- 802.1Q-2005 (formerly 802.1s) MSTP

IETF RFC Compliance

- RFC768-UDP
- RFC783-TFTP
- RFC791-IP
- RFC792-ICMP
- RFC793-TCP
- RFC826-ARP
- RFC854-Telnet
- RFC894-IP over Ethernet
- RFC1112-IGMP v1
- RFC1519-CIDR
- RFC1541-DHCP (client)
- RFC2030-SNTP
- RFC2068-HTTP
- RFC2236-IGMP v2
- RFC2284-EAP
- RFC2475-Differentiated Services
- RFC2865-RADIUS
- RFC3414-SNMPv3-VSM
- RFC3415-SNMPv3-VACM

IETF SNMP MIBS

- RFC1493-BRIDGE-MIB
- RFC1907-SNMPv2-MIB
- RFC2012-TCP-MIB
- RFC2013-UDP-MIB
- RFC2578-SNMPv2-SMI
- RFC2579-SNMPv2-TC
- RFC2819-RMON-MIB
- RFC2863-IF-MIB
- draft-ietf-bridge-rstpmib-03-BRIDGE-MIB
- draft-ietf-bridge-bridgemib-smiv2-03-RSTP-MIB
- IANAifType-MIB

Fiber Specifications and Mechanical Drawing

| Fiber Optical Specifications | | | | |
|------------------------------|--------------------|----------------|----------------|----------------|
| Parameter | Fiber Port Type | | | |
| Mode | Multimode | Singlemode | Singlemode | Singlemode |
| Connector | LC, LC-SFP | SC, LC, LC-SFP | SC, LC, LC-SFP | LC-SFP |
| Typical Dist. | 500m | 10km | 25km | 70km |
| Optical Wavelength (nm) | 850 | 1310 | 1310 | 1550 |
| Cable SizeCore/Cladding (um) | 50/125 or 62.5/125 | 8/125 or 9/125 | 8/125 or 9/125 | 8/125 or 9/125 |
| TX Power (Min/Max) (dBm) | -9.5/-4 | -9/-3 | -7 / 3 | 0 / 5 |
| RX Sensitivity (dBm) | -20 | -22 | -26 | -23 |
| RX Saturation (dBm) | 0 | -3 | -3 | 0 |
| Typical Budget (dB) | 14 | 17 | 19 | 25 |

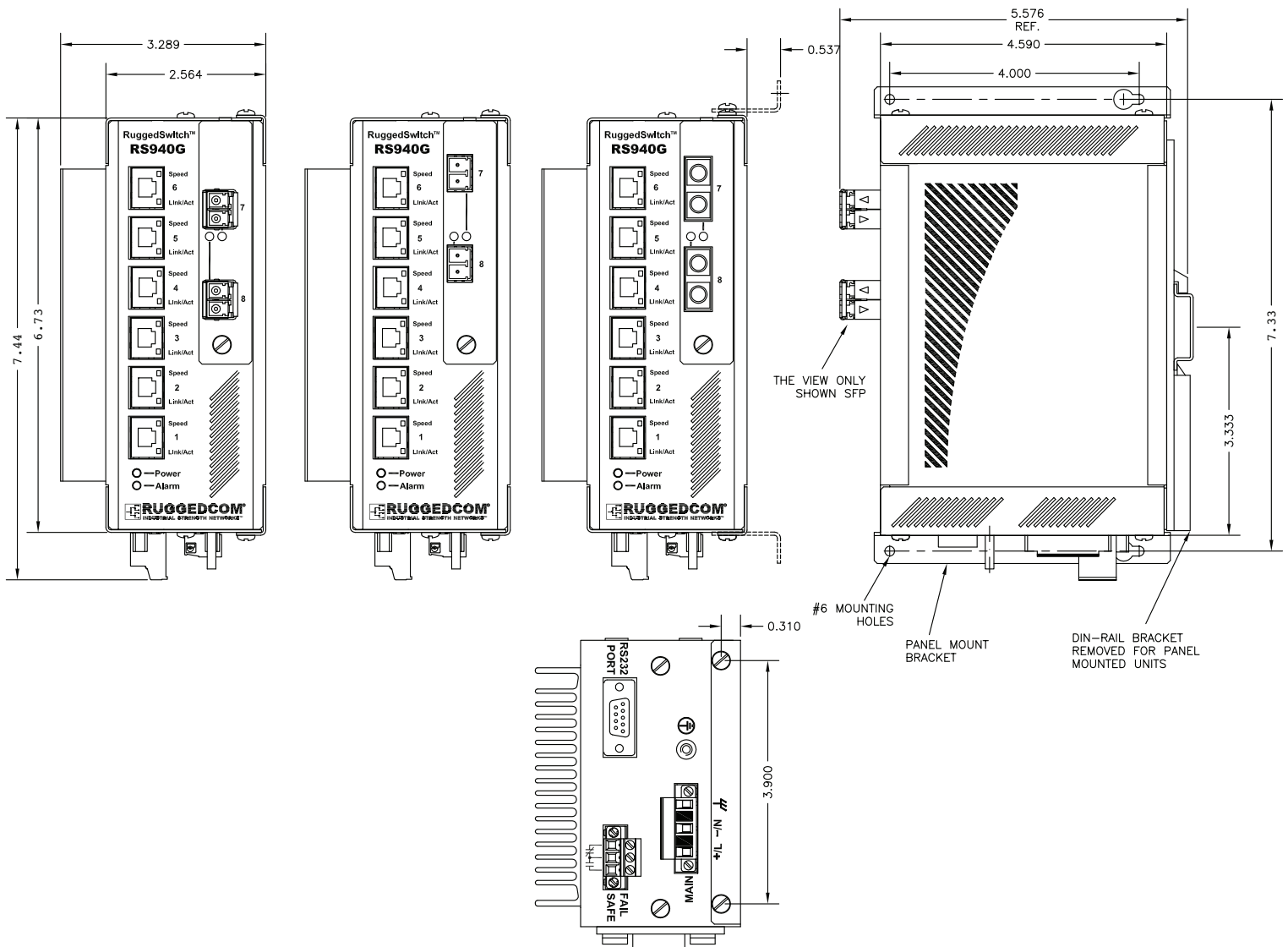

Order Codes

RS940G - - - -
 PS M P7P8 MOD

Base unit includes 6 - 10/100/1000 BaseTX ports

PS: Power Supply

- 24 = 24 VDC (10-36 VDC)
- 48 = 48 VDC (36-72 VDC)
- HI = 88-300VDC or 85-264VAC

M: Mounting Option

- D = DIN Rail
- P = Panel Mount
- N = None

P7P8: Transceiver Options:

- XXXX = None
- 2TX = Dual 10/100/1000TX RJ45
- 2SFP = Dual 1000X SFP (Mini-GBIC). Order SFP Optics Separately.
- 2LCMM = Dual 1000SX Multimode LC 850nm 500m
- 2LC10 = Dual 1000LX Singlemode LC 1310nm 10km
- 2LC25 = Dual 1000LX Singlemode LC 1310nm 25km
- 2SC10 = Dual 1000LX Singlemode SC 1310nm 10km
- 2SC25 = Dual 1000LX Singlemode SC 1310nm 25km

SFP (Mini-GBIC) Transceiver Options (1) (2):

- 25-10-0111 = 1000SX SFP, Multimode, LC, 850nm, 500m^{(1) (3)}
- 25-10-0100 = 1000LX SFP, Singlemode, LC, 1310nm, 10 km⁽¹⁾
- 25-10-0101 = 1000LX SFP, Singlemode, LC, 1310nm, 25 km⁽¹⁾
- 25-10-0109 = 1000LX SFP, Singlemode, LC, 1550nm, 70 km^{(1) (3)}

MOD: Manufacturing Modifications

- XX = None
- C01 = Conformal Coating

Notes:

1 Distance ratings are typical but will depend on type of cabling, number of connectors and splices.

2 Should you not find an appropriate fiber optic option listed here, please consult RuggedCom for other options.

3 These transceivers have an operating temperature range of -20 to +85°C. All other transceivers have an operating temperature range of -40° to +85°C.

RuggedCom Inc.

300 Applewood Crescent, Unit 1,
Concord, Ontario, Canada L4K 5C7

Tel: +1 (905) 856-5288 **Fax:** +1 (905) 856-1995

Toll Free: 1 (888) 264-0006

Technical Support Center

Toll Free (USA & Canada): 1 (866) 922-7975

International: +1 (905) 856-5288

USA: +1 (954) 922-7975

E-mail: Support@RuggedCom.com

© 2010 RuggedCom Inc.
RuggedSwitch is a registered trademark of RuggedCom Inc.
Ethernet is a trademark of the Xerox Corporation.
Patent Pending
All specifications in this document are subject to change without notice.
Rev 1j — 04/27/10

For additional information on our products and services, please
visit our web site at: www.RuggedCom.com